

# Assembly instruction Slidelock

Secure one screw onto the connector flange with the flat washer, lockwasher and hex nut. Tighten the screw to a torque between 11 - 22 Ncm.

Slide the front side of the slide latch over the installed screw to hold the slide lock in position. Thread the remaining screw onto the other side of the connector flange with the hardware and tighten to a torque between 11 - 22 Ncm.

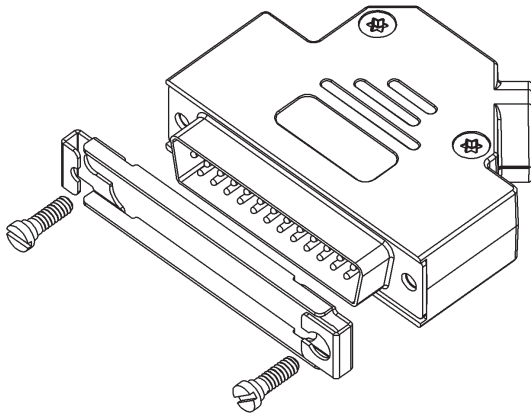

Push the slide lock from side to side to ensure proper movement.

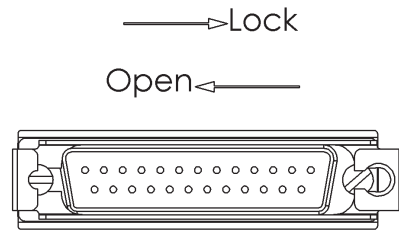

Insert the locking post into the front of the connector flange. Secure the locking post with the flat washer, locking washer and nut.

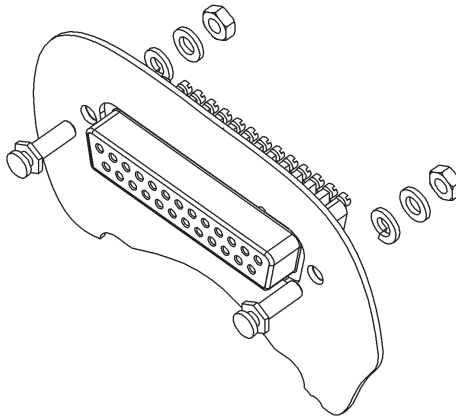

Disengage the connectors with slide lock as follows:

- 1) Move the slide lock from side to side until snaps into the the unlocking position.
- 2) Grasp the connectors and pull straight apart.

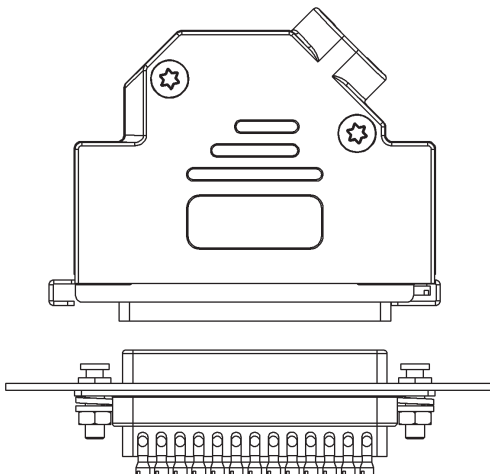

Engage the connector with slide lock as follows:

- 1) Position the slide lock so that the large latch opening is directly over a slide lock screw.
- 2) Align the connector mating faces and plug the two connectors together.
- 3) Move slide lock from side to side to lock the two connectors together.

