

Assembly instruction DTZK-CZA Series

Prepare cable as illustrated below. Slide crimp ferrule over the outer cable jacket.

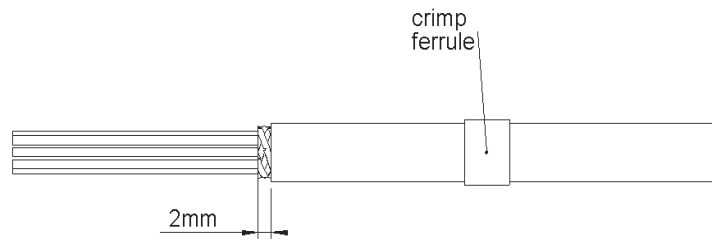

Put wires through and shape cable metal braid around the anchor ferrule.

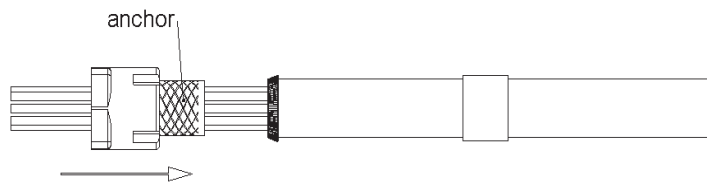

Slide the crimp ferrule into position over outer cable jacket aligned with the anchor ferrule.

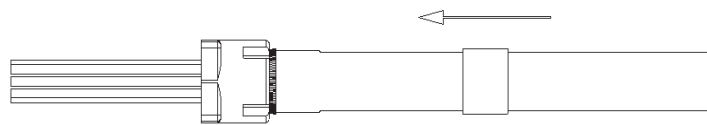

Crimp over the crimp ferrule and mount the D-Sub connector.

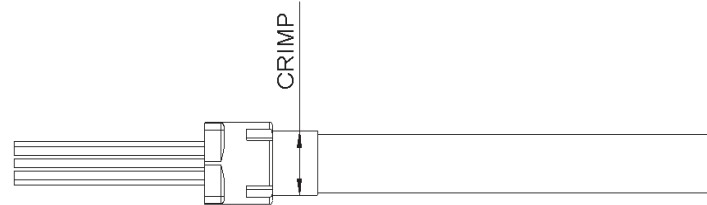

Place the assembled connector and crimped cable into the bottom back shell half.

Complete the assembly by putting the top half over the assembly and tighten with accompanied assembly screws. Maximum mounting torque is 100 - 120 Ncm.

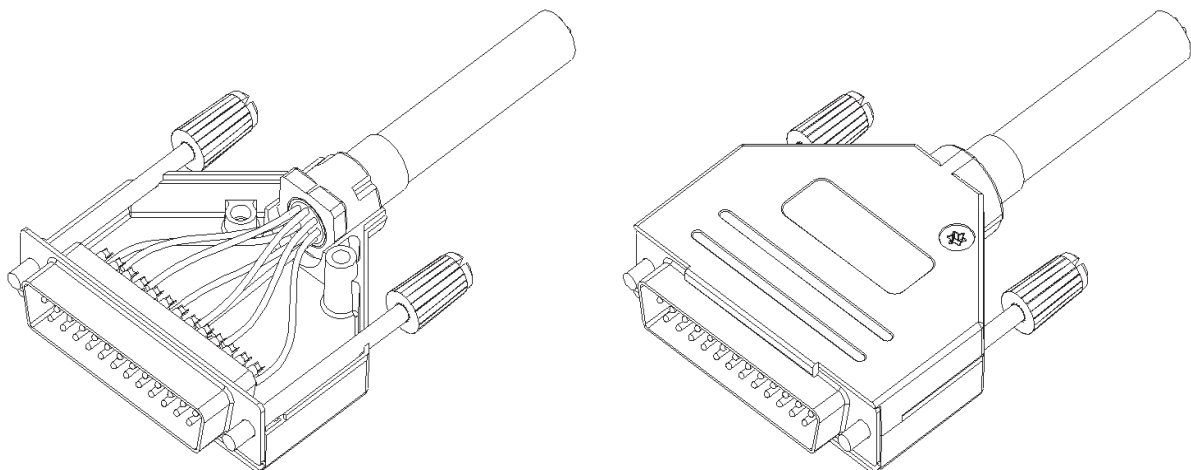

Assembly instruction DVZK-CZA Series

Prepare cable as illustrated below. Slide crimp ferrule over the outer cable jacket.

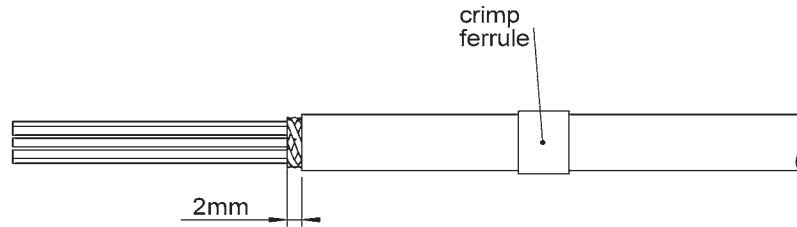

Put wires through and shape cable metal braid around the anchor ferrule.

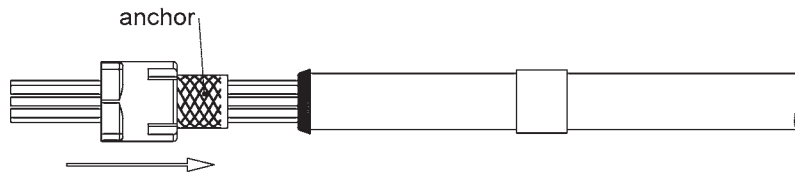

Slide the crimp ferrule into position over the outer cable jacket aligned with the anchor ferrule.



Crimp over the crimp ferrule and mount the D-Sub connector.

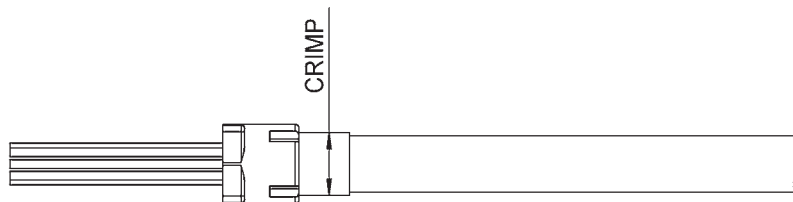

Place the assembled connector and crimped cable into the bottom back shell half.

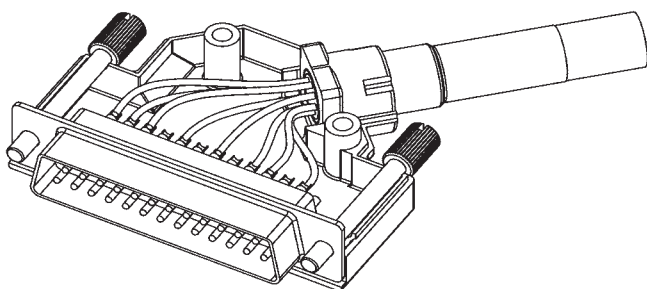

Complete the assembly by putting the top half over the assembly and tighten with accompanied assembly screws. Maximum mounting torque is 100 - 120 Ncm.

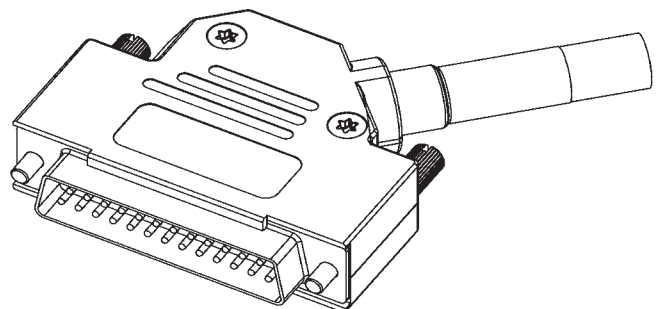

Assembly instruction DTZK-CZAK Series

Prepare cable as illustrated below. Slide crimp ferrule and plastic heat shrink tube over the outer cable jacket.

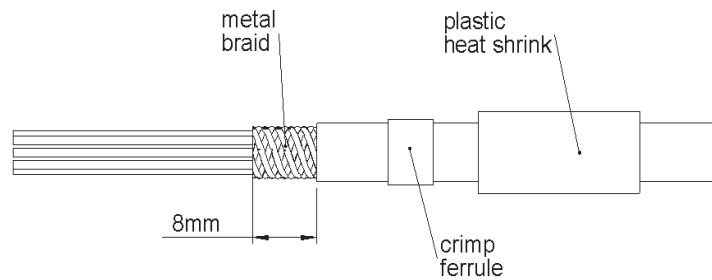

Put wires through and shape cable metal braid around the anchor ferrule.

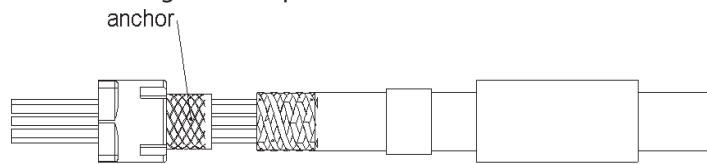

Slide the crimp ferrule into position over outer cable jacket aligned with the anchor ferrule. Crimp over the crimp ferrule and mount the D-Sub connector.

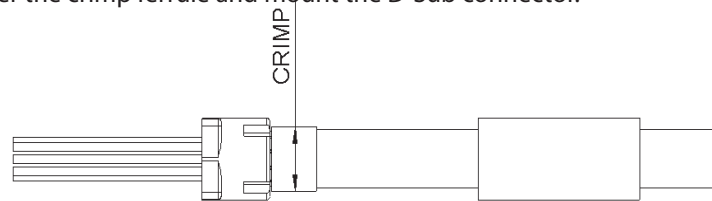

Slide the heat shrink tube over the crimped ferrule and melt the material until securely fastened over the ferrule.

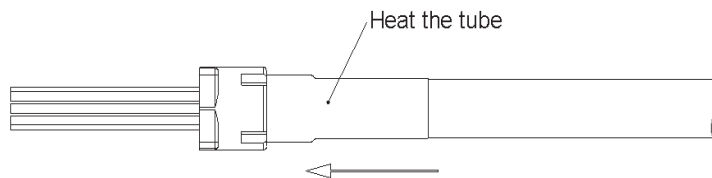

Place the assembled connector and crimped cable into the bottom back shell half.

Complete the assembly by putting the top half over the assembly and tighten with accompanied assembly screws. Maximum mounting torque is 100 - 120 Ncm.

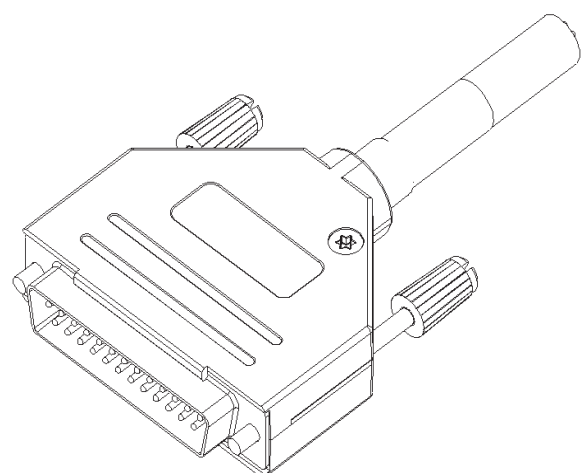
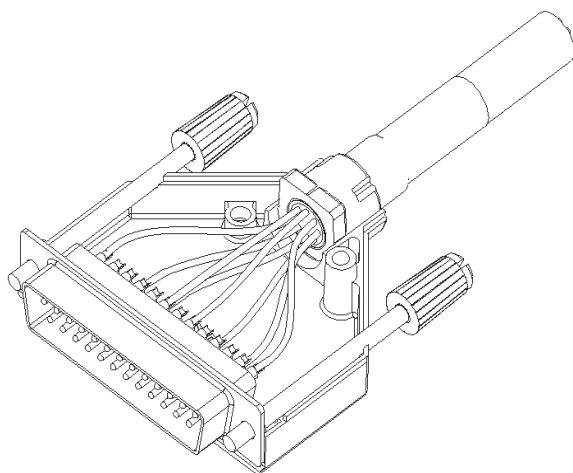

Assembly instruction DVZK-CZAK Series

Prepare cable as illustrated below. Slide crimp ferrule and plastic heat shrink tube over the outer cable jacket.

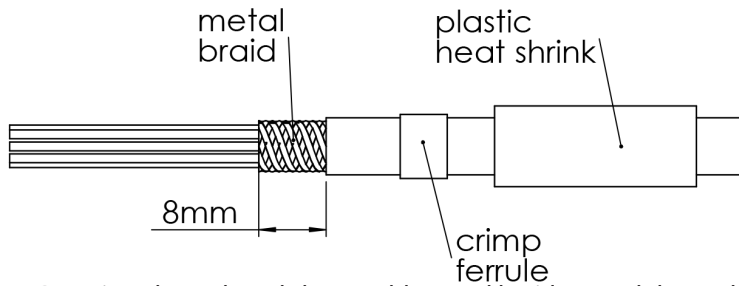

Put wires through and shape cable metal braid around the anchor ferrule.

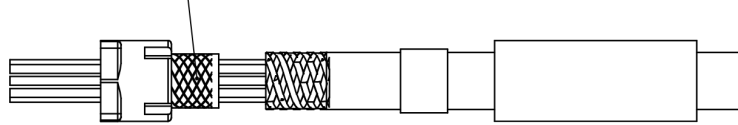

Slide the crimp ferrule into position over outer cable jacket aligned with the anchor ferrule. Crimp over the crimp ferrule and mount the D-Sub connector.

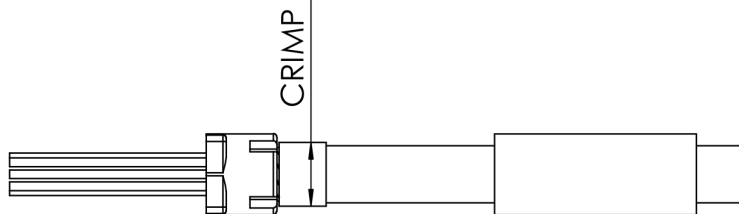

Slide the heat shrink tube over the crimped ferrule and melt the material until securely fastened over the ferrule.

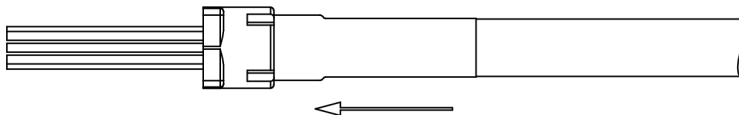

Place the assembled connector and crimped cable into the bottom back shell half.

Complete the assembly by putting the top half over the assembly and tighten with accompanied assembly screws. Maximum mounting torque is 100 - 120 Ncm.

