

# Assembly instruction DPPK-2 Series

Decide if option A (cable diameter 9 - 11 mm), option B (cable diameter 5 - 9 mm) or option C (cable diameter < 5 mm) is applicable. Depending on the cable diameter, back shell is assembled either without cable grommet or cable grommet facing upwards or downwards. Size 9 version is assembled without the cable grommet and cable clamp.

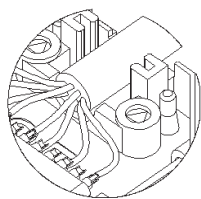

A

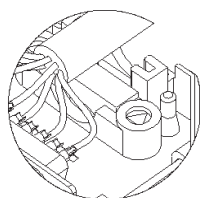

C

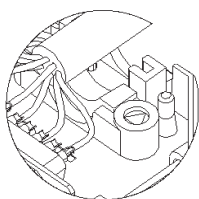

B

Place the mounted cable and connector inside the back shell. Mount the cable clamp with the two accompanied assembly screws. Maximum mounting torque is 100 - 120 Ncm. Strain relief kit is provided as an option for size 25 version and delivered as standard for the size 9 version.

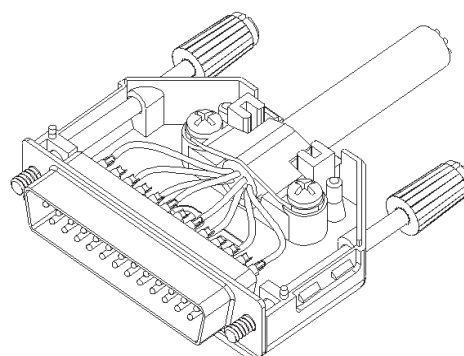
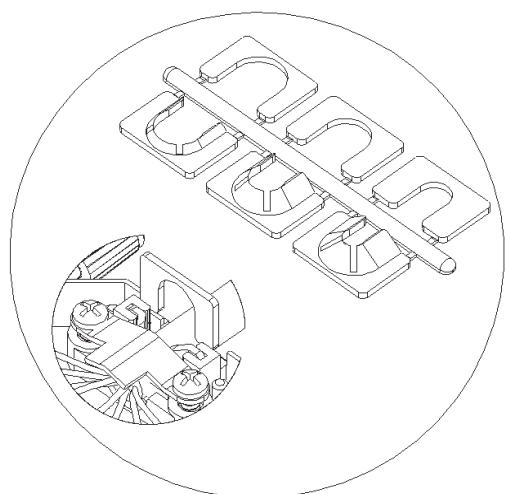
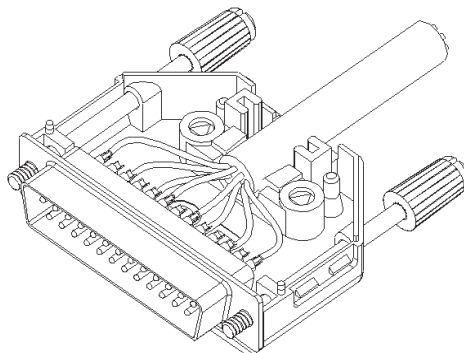

Close the connector hood by clicking bottom and top half together. Assembly is now completed.

