

Assembly instruction DVNMK Series

Use two halves of the strain relief and attach around the outer cable jacket. Different sizes of the strain relief can be mixed together to give the best fit. For cable diameters exceeding 9 mm, assembly without the strain relief or with just one strain relief half is applicable.

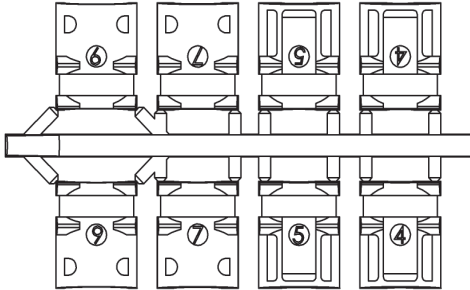

Strip the outer cable jacket 18 mm as illustrated below.

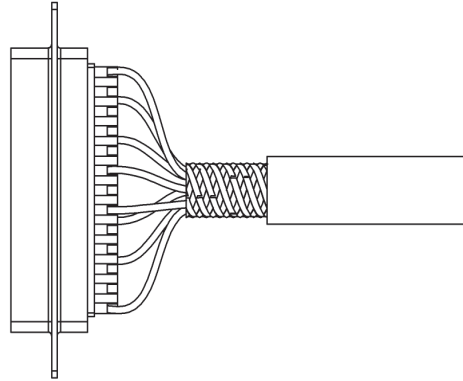

Split and pigtail the braid as illustrated below.

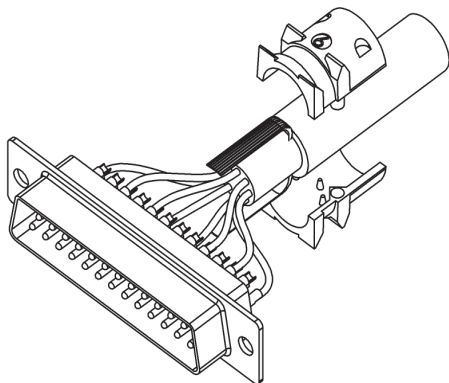

Turn the pigtail cable shield back over the strain relief. If not using any strain relief from the supplied set, use the same procedure around the outer cable jacket.

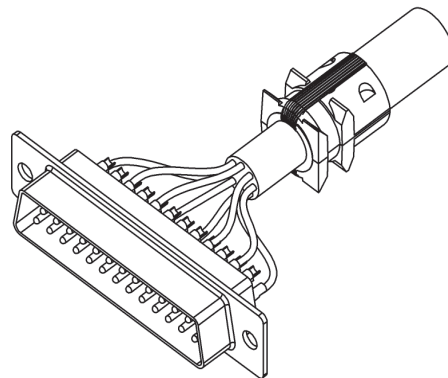

Place the assembled connector and cable into the bottom back shell half.

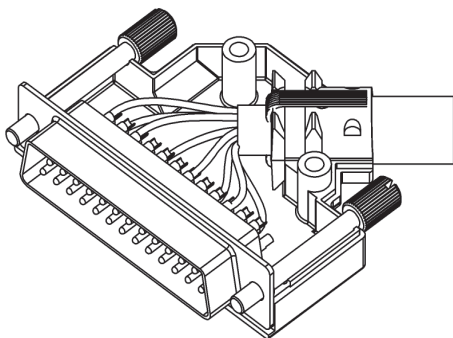

Complete the assembly by putting the top half over the assembly and tighten with accompanied assembly screws. Maximum mounting torque is 100 - 120 Ncm.

